

## **VITAL SAFETY INFORMATION for Hunke Pump Hoist operation**

**Read carefully before operating your pump hoist and review often.  
Pay close attention! This information may save your life or livelihood!**

The manufacturer cannot possibly imagine all the different possibilities and situations that can occur to warn against. You, the owner, operator or member of the work crew, must use every safety precaution to protect yourself and those around you from injury or death.



### **WARNING!**

Failure to follow these instructions can cause serious injury or death.

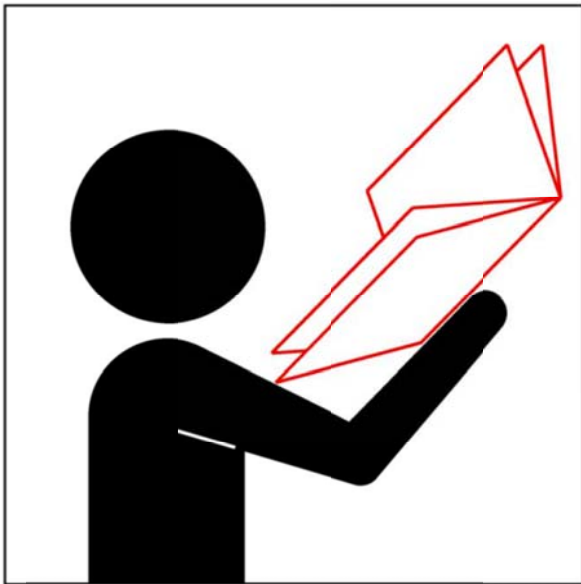

The inspection and maintenance procedures as directed in the Operator's Manual and Safety Document must be followed to keep your Hunke pump hoist operating safely. Any problems must be corrected before operating the pump hoist.

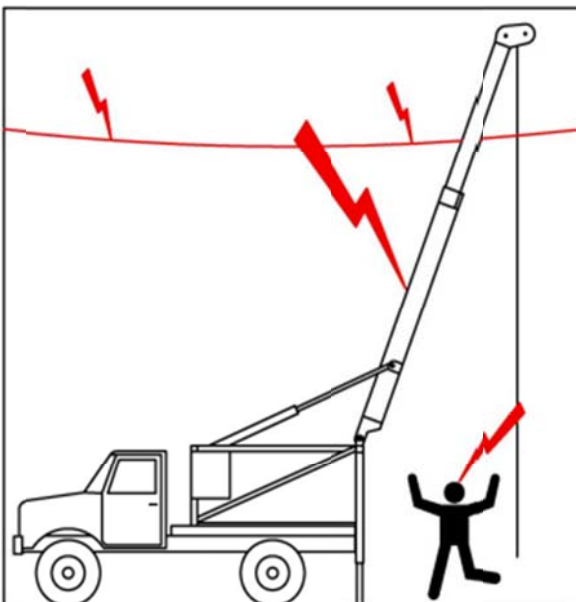

This pump hoist cannot be insulated against electric shock!

If any part of this machine comes within close proximity of an electric power line the charge will be carried through the machine to anyone touching it and possibly to anyone near it.

If power lines are in the work area, contact the power company to de-energize the power lines.

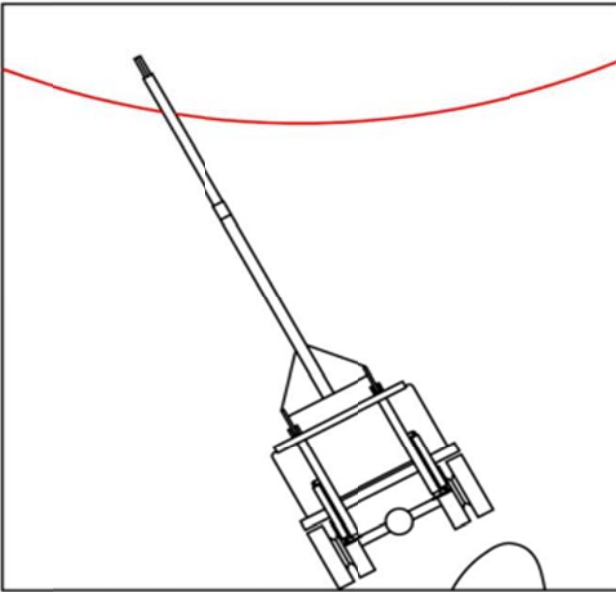

DO NOT move the pump hoist with the mast up.

There is danger of tipping and there may be unnoticed power lines or other obstacles along the intended route.

This pump hoist is not a mobile crane.



Anyone in or near the work area must wear a hard hat at all times.

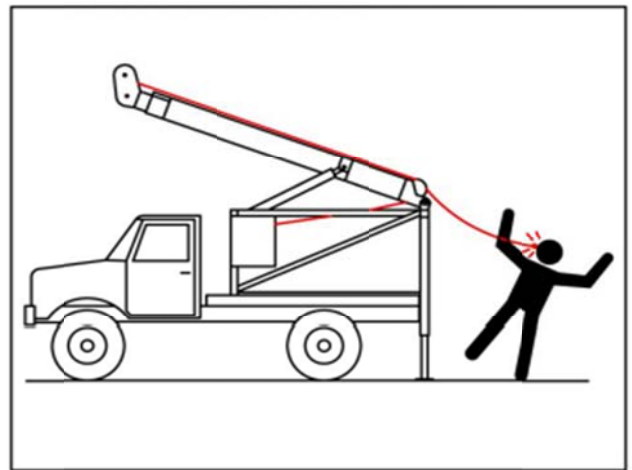

DO NOT erect or lower the mast without sufficient slack in all the cables.

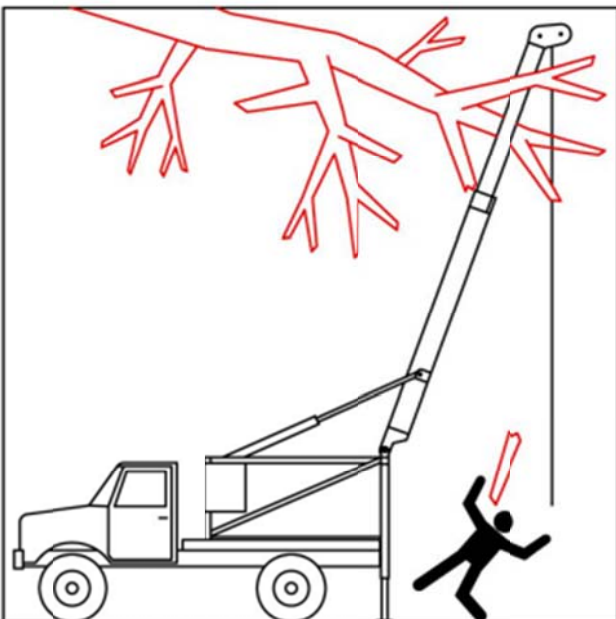

DO NOT set the mast up into tree branches or other overhead obstructions.

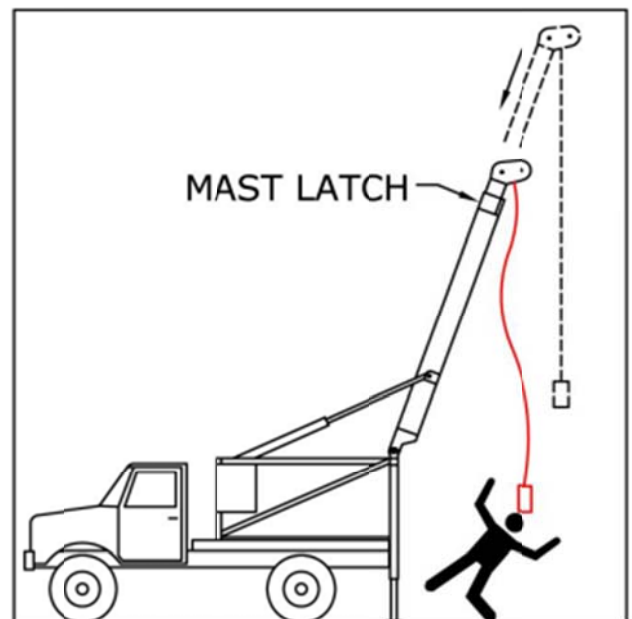

DO NOT lift a load if the mast extension latch is not completely engaged.

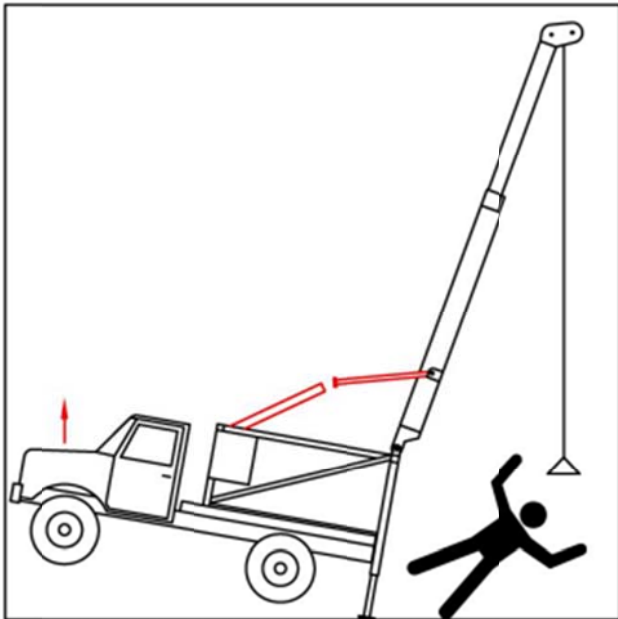

DO NOT exceed the rated load. DO NOT lift a load that causes the front wheels to be lifted off the ground.

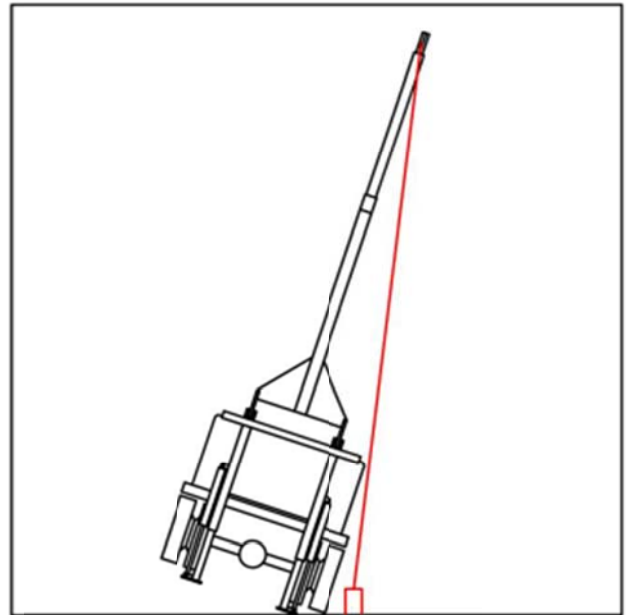

DO NOT lift a load that is not centered with the mast.

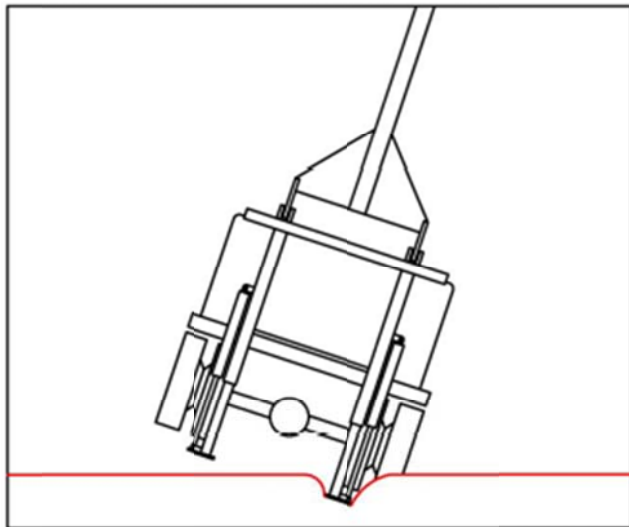

DO NOT lift a load if the outriggers are not on a solid base.

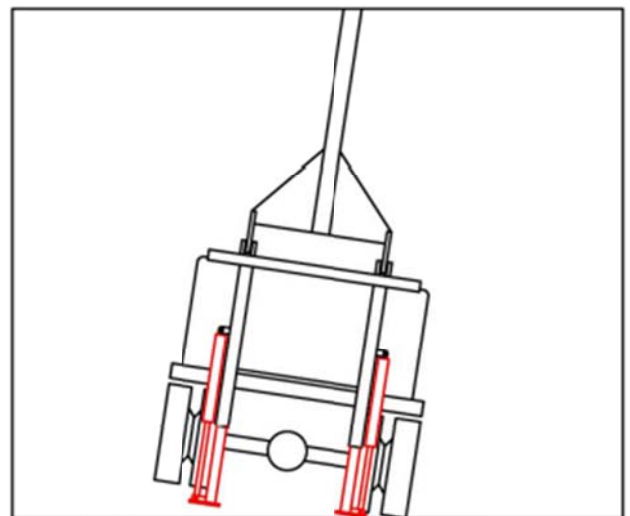

DO NOT re-level the pump hoist with a load on the mast.

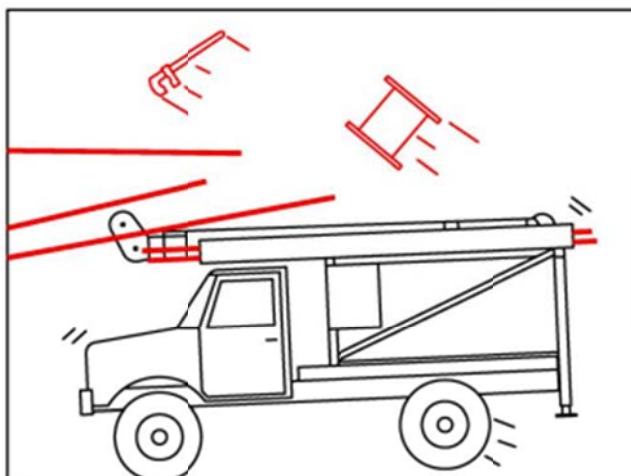

All items in pipe racks or in the pump hoist area or anywhere on the vehicle must be strapped or secured before moving the vehicle.

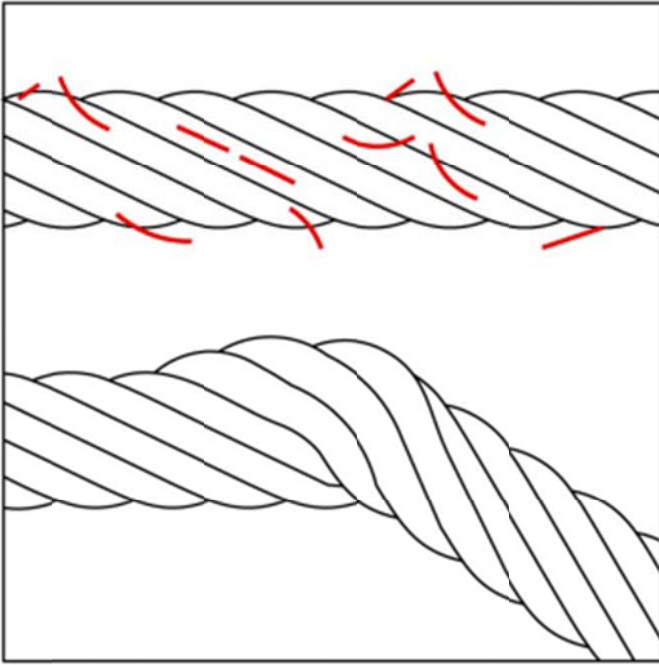

DO NOT operate the pump hoist with a damaged cable.

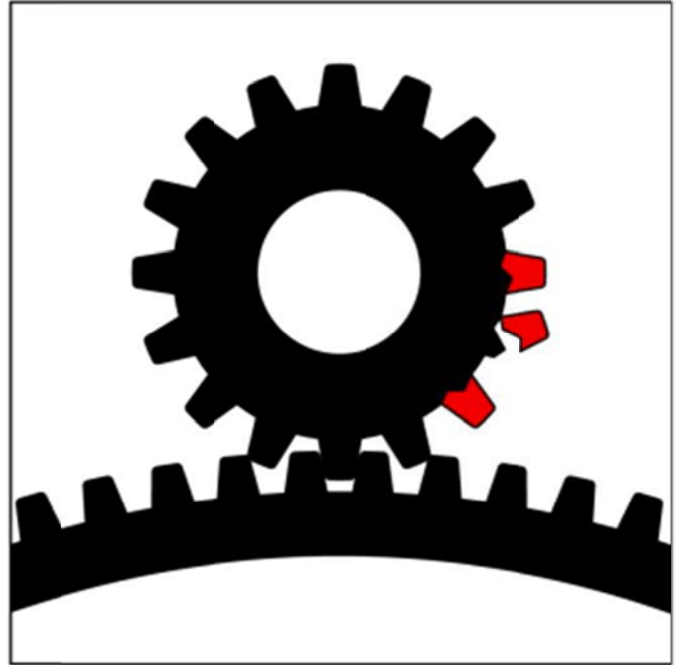

DO NOT operate the pump hoist if gears have broken, cracked or worn teeth.

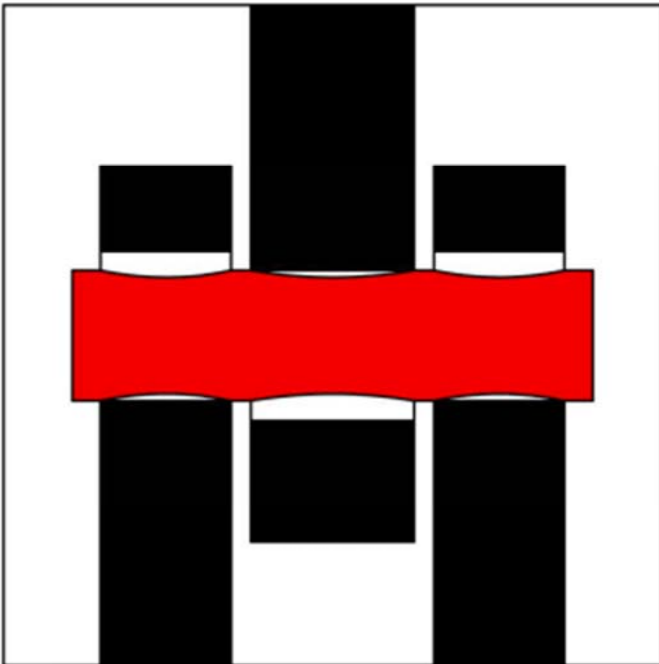

DO NOT operate the pump hoist if any parts are excessively worn.

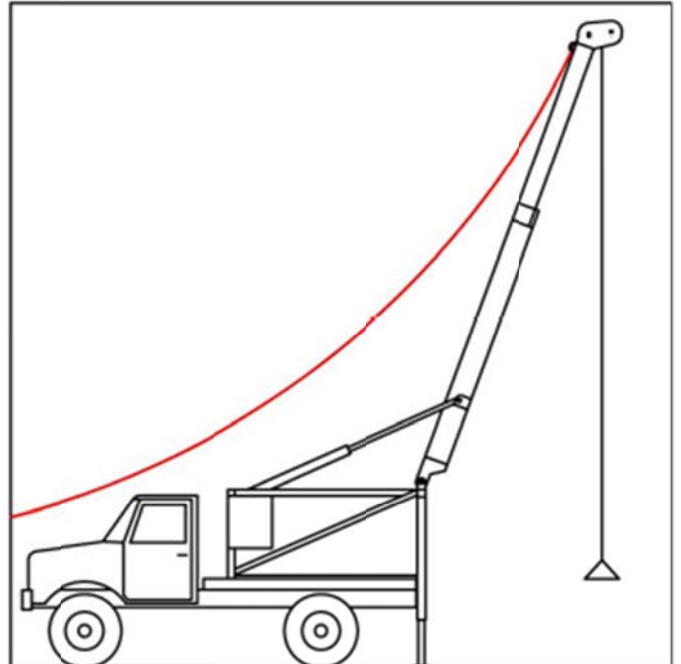

DO NOT operate the pump hoist with improperly adjusted guy cables. A loose guy line will not support the mast.

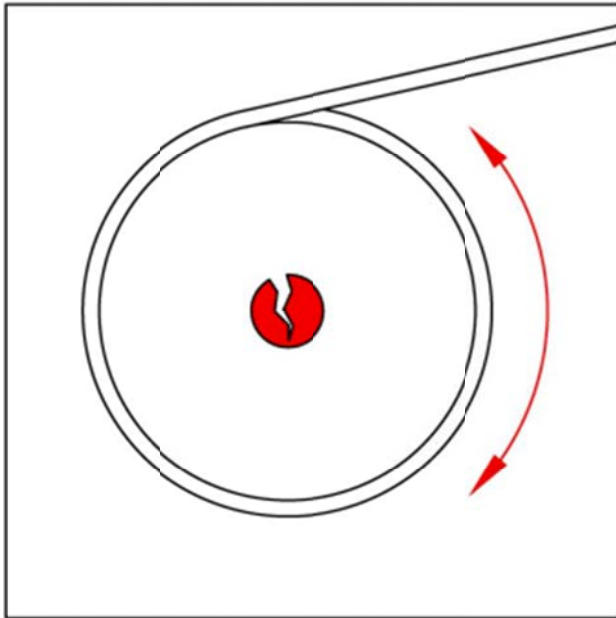

DO NOT change winch direction unless the winch drum is completely stopped.

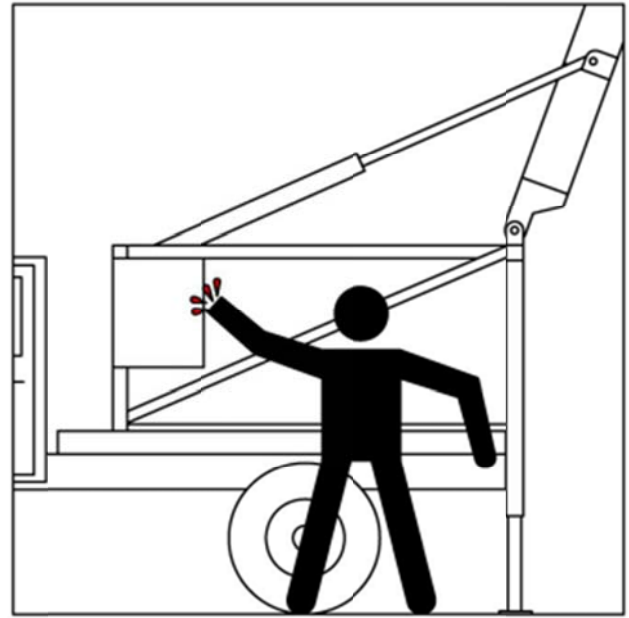

Be aware of moving parts and parts that can come into motion.

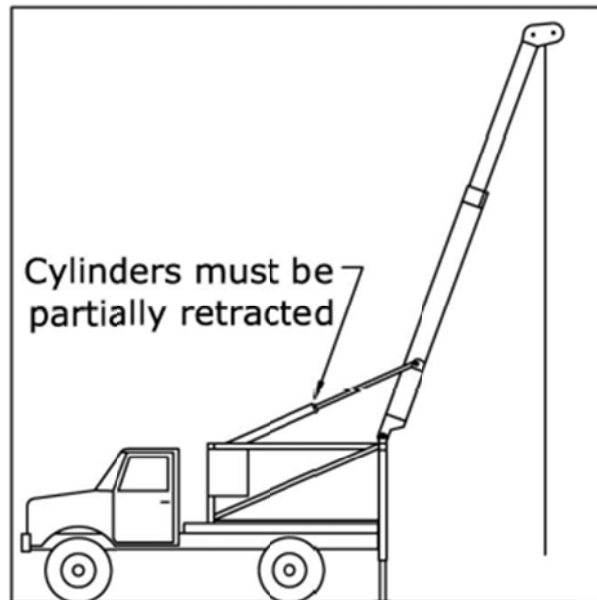

DO NOT lift a load with the mast in maximum layback position.

## HUNKE MANUFACTURING LLC

801 W. 4<sup>th</sup> Street

P.O. Box 128

Snyder, NE 68664

PHONE: 402-568-2221

FAX: 402-568-2223

E-mail: [sales@hunkemfg.com](mailto:sales@hunkemfg.com)

Website: [www.hunkemfg.com](http://www.hunkemfg.com)

